

# Instruction Manual

## Remote Flowmeter - Pulsar RFP Series

### CONTENTS

Unpacking.....	2
Location .....	2-3
Programmable Divider & Pump Calculations.....	4
Dimensions & Weights.....	7
Specifications.....	10
Parts List .....	11

For file reference, please record the following data:

Model No: \_\_\_\_\_

Serial No: \_\_\_\_\_

Installation Date: \_\_\_\_\_

Installation Location: \_\_\_\_\_

When ordering replacement parts for your LMI Controller or accessory, please include the complete Model Number and Serial Number of your unit.



8 Post Office Square  
Acton, MA 01720 USA  
TEL: (508) 263-9800  
FAX: (508) 264-9172  
<http://www.lmipumps.com>



# INSTALLATION

## I. UNPACKING

A. Remote Flowmeter (RFP) units are packaged in two separate cartons. One carton contains the Flowmeter and 10 feet of cable for direct hookup to the Remote Programmable Divider. The other carton contains the Remote Programmable Divider complete with 10 feet of cable for direct connection to an LMI metering pump.

B. Remote Flowmeter units in 3/4", 1", and 1 1/2" sizes have a pair of union couplings and gaskets included. The 2", 3", 4" and 6" sizes have flange connections.

C. Because of test water residue, the Remote Flowmeter should be stored in a frost-proof area. If this is not possible, the Remote Flowmeter must be thawed prior to installation.

## II. LOCATION

### A. Flowmeter

1. Remote Flowmeters should be installed in a frost-proof, easily accessible area.

2. To prevent accumulation of air and a resultant error in measurement, the Flowmeter should be installed on the lowest horizontal point of the pipeline.

3. An uninterrupted run of straight pipe with a length at

least 10 times the nominal diameter of the Flowmeter both upstream and downstream is need to ensure accurate readings.

4. If the pipe line downstream from the Flowmeter is open discharge, the pipe must be raised so open discharge elevation is higher than the top of the Flowmeter (see "Typical Installation" drawing below).

5. Thoroughly rinse the pipeline by opening the upstream shut-off valve before installing the Flowmeter.

6. The Remote Programmable Divider may be located as far as 100 feet from the Flowmeter location. Extension cables are available. Please consult the factory if the Remote Programmable Divider will be installed more than 100 feet from the Flowmeter.

7. The flowmeter must be installed horizontally and level, with the glass register positioned up (12:00 position--see "Typical Installation" drawing).

8. For ease of installation, install a shut-off valve, with an orifice diameter at least as large as the nominal size of the Flowmeter. Installation of a bypass is also recommended for easy removal or servicing of the Flowmeter without interrupting the water flow (see "Typical Installation" drawing).

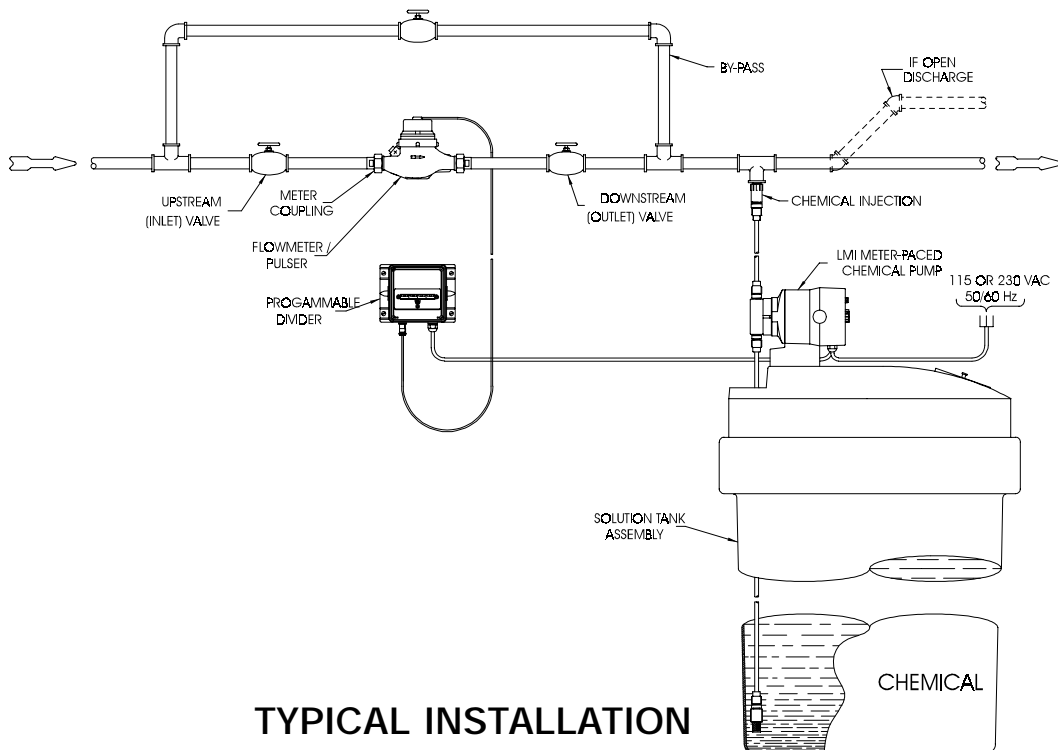

TYPICAL INSTALLATION

9. Apply Teflon tape or pipe thread sealant on tapered pipe thread ends of the meter couplings on 3/4", 1" or 1 1/2" models.

10. Air trapped in the Flowmeter should be removed prior to operation. To accomplish this, loosen the meter couplings slightly (for models so equipped) and rotate the Flowmeter slowly so that register is upside down. Open upstream (inlet) valve slowly letting water through the meter. Rotate Flowmeter slowly again until the register is upright and tighten meter couplings. The Flowmeter is now ready for cable connection to the Remote Programmable Divider.

## B. REMOTE PROGRAMMABLE DIVIDER

1. The Remote Programmable Divider may be located up to 100 feet from the Flowmeter. The unit has molded-in 4 mounting holes that will accept 1/4" diameter screws for wall mounting.

2. Once the Remote Programmable Divider and the Flowmeter have been installed, connect the cable from the Flowmeter to the programmable divider by plugging the connector on the cable into the receptacle on the programmable divider.

## C. METERING PUMP

1. Installation of your LMI metering pump should be in accordance with instructions included with the pump.
2. Plug the connector from the programmable divider into the receptacle located on the bottom of the pump's control panel.
3. To prime the pump, switch to the INTERNAL mode and follow the PRIMING PROCEDURES on the LIQUID END ASSEMBLY INSTRUCTION SHEET. Once the pump is primed, switch to the EXTERNAL mode for meter pacing.
4. Set divider number on the programmable divider according to instruction in the next section.
5. Check treated water for desired dosage.
6. Adjust stroke length knob until desired dosage is obtained.

### IMPORTANT:

**PUMP MUST BE IN THE EXTERNAL MODE FOR METER PACING.**

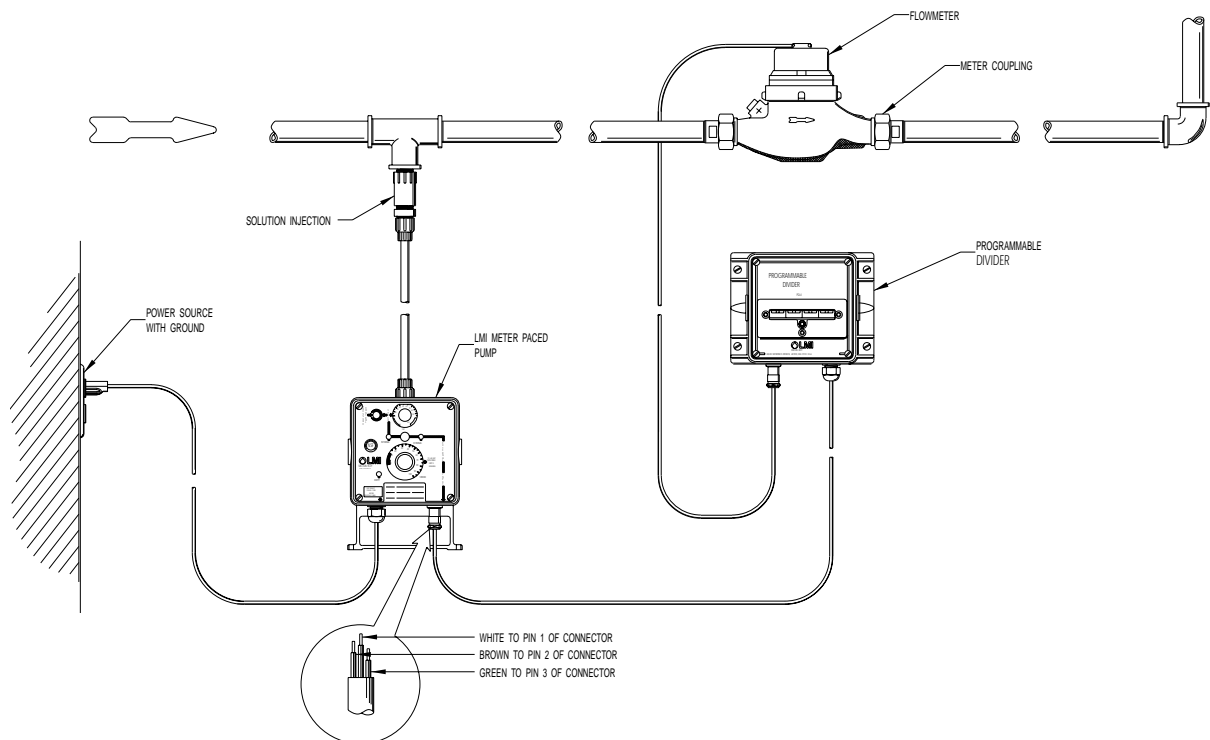

## CONNECTOR INSTALLATION

### III. PROGRAMMABLE DIVIDER AND PUMP CALCULATIONS

The following information is provided to enable you to understand the calculations necessary to properly adjust your RFP flowmeter. In the steps below you will calculate:

- A - Required pump output
- B - Maximum output of metering pump
- C - Percent output required from pump
- D - Stroke knob setting on pump (strokes per minute)
- E - Divider number

#### 1. DETERMINE METERING PUMP OUTPUT (GPH\*)

- Be sure the metering pump selected is an LMI A7, B7 or C7 type pump. These pumps are equipped with an external input jack for use with RFP flowmeters.
- When using the A7, B7 or C7 pump with an RFP flowmeter, the speed control knob function is bypassed and taken over by the divider unit. The speed of the pump is controlled automatically, based on the flow of the water through the flowmeter. On the LMI A7 pump external mode is accomplished by turning the speed knob fully counter clockwise. On B7 and C7 pumps, a switch is provided to place the pump in the external mode.
- Be sure the pump's pressure rating exceeds the system pressure by a minimum of 20%. For example, if system pressure equals 100 psi, the pump rating should be 120 psi or greater.
- Use this calculation to determine output in gallons per hour (GPH\*).

$$\frac{\text{Max. flowrate of water through flowmeter (in GPM*)} \times \text{Desired concentration (in PPM*)}}{\text{Percent concentration of pumping solution (expressed as a whole number)}} = \boxed{\phantom{000}} \times .006 = \boxed{\phantom{000}} \text{ (A) (Required pump output in GPH*)}$$

Example A:

$$\frac{70 \text{ (GPM*)} \times 4 \text{ (PPM*)}}{5.25 \text{ (\% solution expressed as a whole number)}} = \boxed{53.33} \times .006 = \boxed{.32} \text{ (A)}$$

Example Results: Select an A77 pump with  $\boxed{.42} \text{ (B)}$  GPH\* max. output at 140 psi. (Use the pump selection guide.)

**2. DETERMINE PERCENT OUTPUT REQUIRED FROM PUMP**

$$\frac{\text{Required pump output from (A)}}{\text{Max output of metering pump selected (in GPH*) (B)}} = \boxed{\text{(C)}} \text{ (percent output required from the pump)}$$

Example B:

$$\frac{\boxed{.32} \text{ (A)}}{\boxed{.42} \text{ (B)}} = \boxed{.76} \text{ (Percent output required from pump)}$$

**3. DETERMINE THE STROKE SETTING**

$$\sqrt{\text{Percent output desired from pump (C)}} = \boxed{\text{(D)}} \text{ (Stroke knob setting on pump and strokes per minute in step 5)}$$

Example C:

$$\sqrt{\boxed{.76} \text{ (C)}} = \boxed{.87} \text{ (Stroke knob setting on pump and strokes per minute in step 5)}$$

Example Result: Set stroke knob to 87%

**4. FLOWMETER SPECIFICATIONS**

Check the size of the flowmeter selected based on:

- The required pipe size or mounting flange.
- The maximum and minimum flowrate of the flowmeter.

Model	Pipe Size	Flow-GPM*		Flow-LPM*		Primary Pulses per U.S Gallon	Primary Pulse per Liter
		MIN	MAX	MIN	MAX		
RFP-07	3/4"	0.44	20	1.7	76	62.7	16.6
RFP-10	1"	0.8	50	3.0	189	34	9
RFP-15	1-1/2"	1.4	85	5.3	322	13.3	3.5
RFP-20	2"	1.75	130	6.6	492	13.3	3.5
RFP-30	3"	5	350	18.9	1325	7.7	2
RFP-40	4"	5	650	18.9	2460	4.8	1.3
RFP-60	6"	9	1300	34.1	4921	1	0.3

**5. DETERMINE DIVIDER NUMBER**

**NOTE:**

If an LMI D7 metering pump is being used, multiply value (D) by 75% to determine correct Divider Number.

$$\frac{\text{Max. flowrate of water through flowmeter (in GPM*)} \times \text{Primary pulses per U.S. gallon (from chart)}}{\text{Strokes per minute of pump (expressed as a whole number) (D)}} = \boxed{\text{(E)}} \text{ Divide number}$$

Example D:

$$\frac{70 \text{ (GPM*)} \times 13.3 \text{ (PPPUSG*)}}{\boxed{87} \text{ (D)}} = \boxed{10.7} \text{ (E) Divide number (round off to nearest whole number)}$$

Example Result:

Round off the divider number to read  $\boxed{0011}$  (E) on the divider unit. The resulting divider number will cause the pump to run at 87 strokes per minute at the maximum flowrate of water through the flowmeter.

**6. SET THE DIVIDER NUMBER**

- A. Remove the clear window on the programmable divider by removing the two black thumb screws.
- B. Set thumbwheel numbers to divider number determined above.

Example:

Using the divider number determined in the previous example (divider number = 0011), you would set the thumbwheels as illustrated below:



- C. Replace the clear window to activate divider.

**IMPORTANT:**

**DIVIDER WILL NOT OPERATE UNLESS CLEAR WINDOW IS IN PLACE.**

**NOTES:**

- To make small increases or decreases in output, adjust the stroke knob.
- Increasing the divider box number will decrease the pump speed (strokes per minute).
- Decreasing the divider box number will increase the pump speed (strokes per minute).
- Dilute pumping solutions when low PPM concentrations are required. This will allow you to increase the pump speed (strokes per minute).

\*GPM=Gallons per Minute \*GPH=Gallons per hour \*LPM=Liters per minute \*PPM=Parts per million  
 \*PPPUSG=Primary pulses per U.S. Gallon

## DIMENSIONS & WEIGHTS

Model No.		RFP-07	RFP-10	RFP-15	RFP-20	RFP-30	RFP-40	RFP-60
Nominal Size	in	3/4	1	1-1/2	2	3	4	6
	mm	20	25	40	50	75	100	150
L	in	7.5	10.25	11.81	10.62	12	14	18
	mm	190	260	300	270	305	356	457
L1	in	11.34	14.87	17.25	-	-	-	-
	mm	288	378	438	-	-	-	-
H	in	5.35	5.79	6.34	8.6	8.440	9.370	12.560
	mm	136	147	161	218	214	240	319
h	in	1.61	1.75	1.81	3.27	3.87	4.62	6
	mm	41	44	46	83	99	117	152
D	in	1	1.25	2	6.5	7.5	9	18
	mm	-	-	-	165	190	228	457
BC	in	-	-	-	4.75	6	7.5	9.5
	mm	-	-	-	121	152	190	241
Bolt Size	in	-	-	-	5/8	3/4	3/4	3/4
	mm	-	-	-	16	19	19	19
No. of Bolts		-	-	-	4	4	8	8
Net Weight	lbs	4.6	6.8	13.0	25.8	42	68	135
	kg	2.1	3.1	5.9	11.7	19.1	30.8	61.2

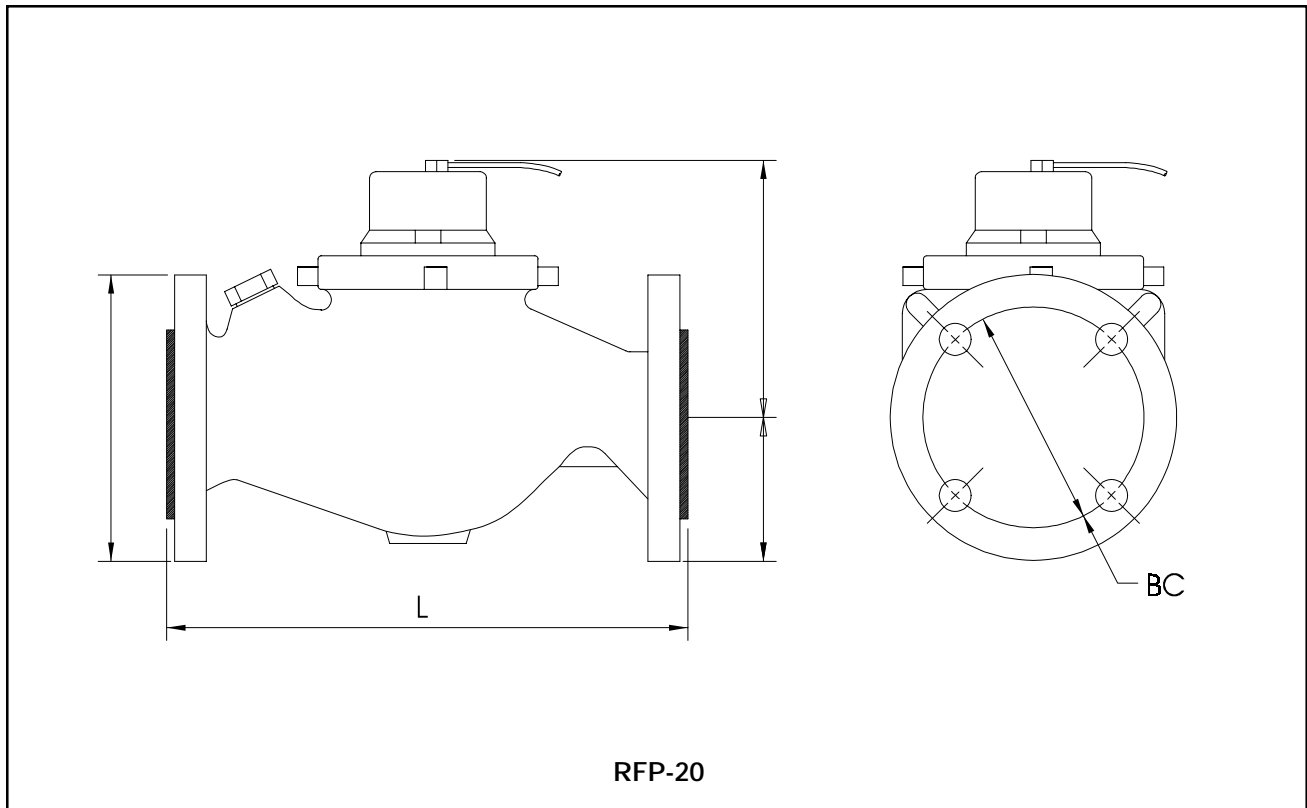
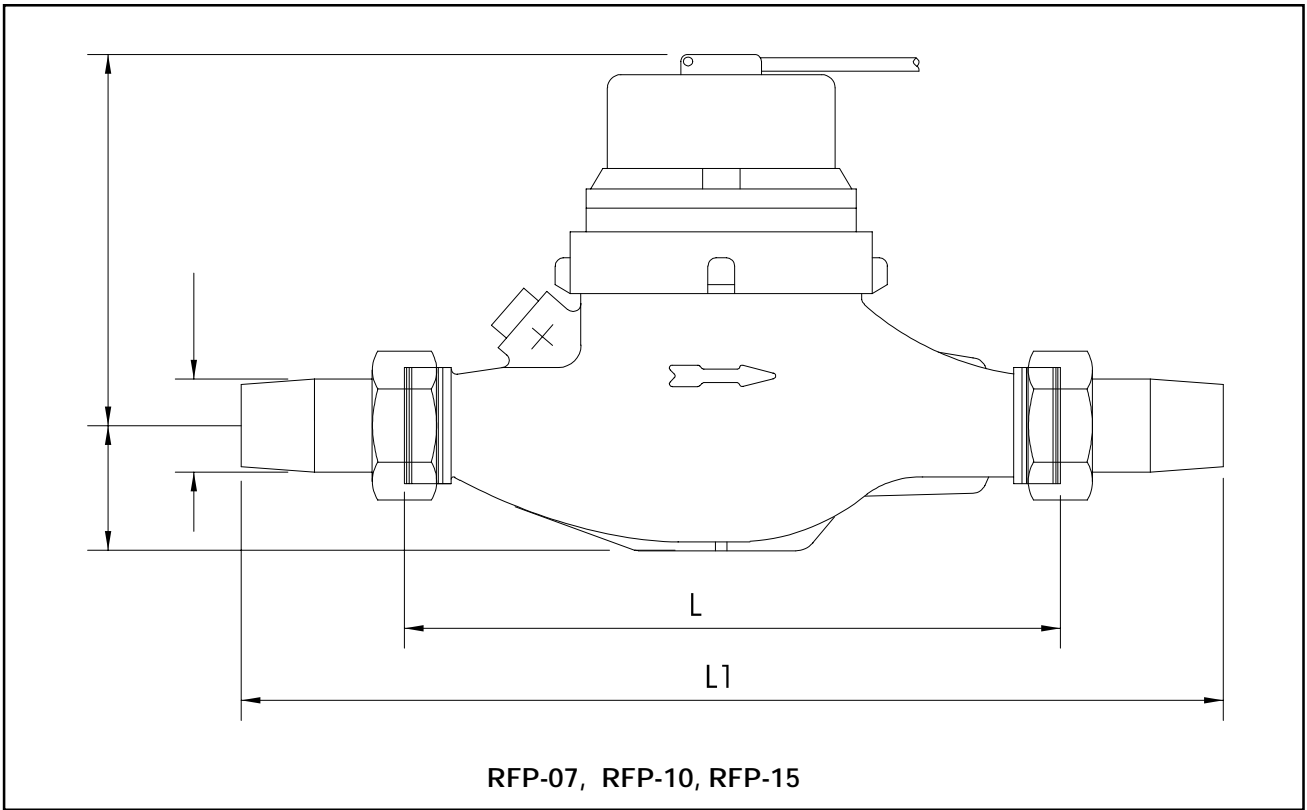

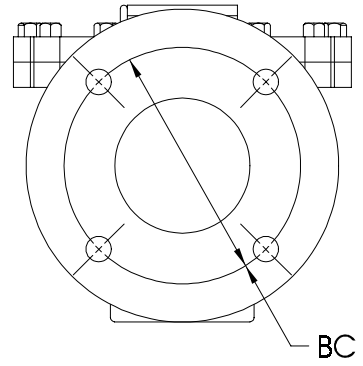
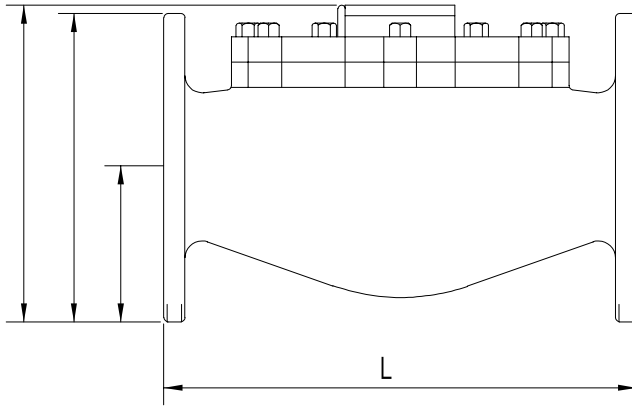

RFP-30

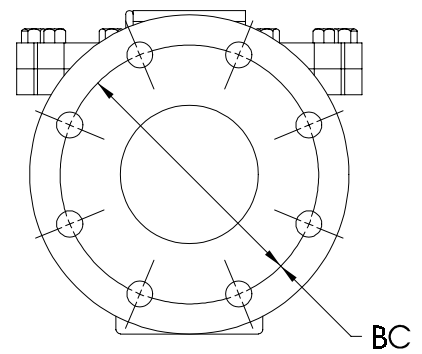
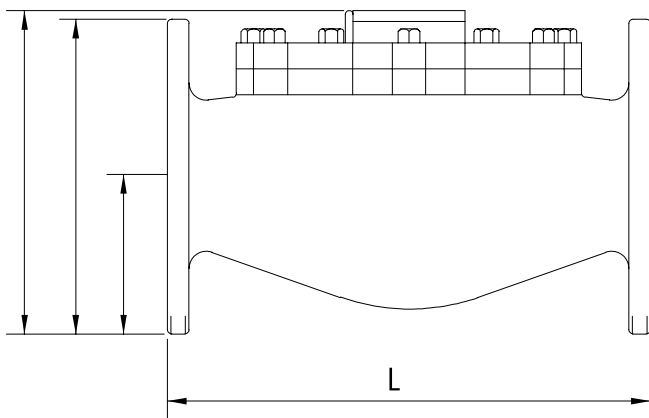

RFP-40 RFP-60

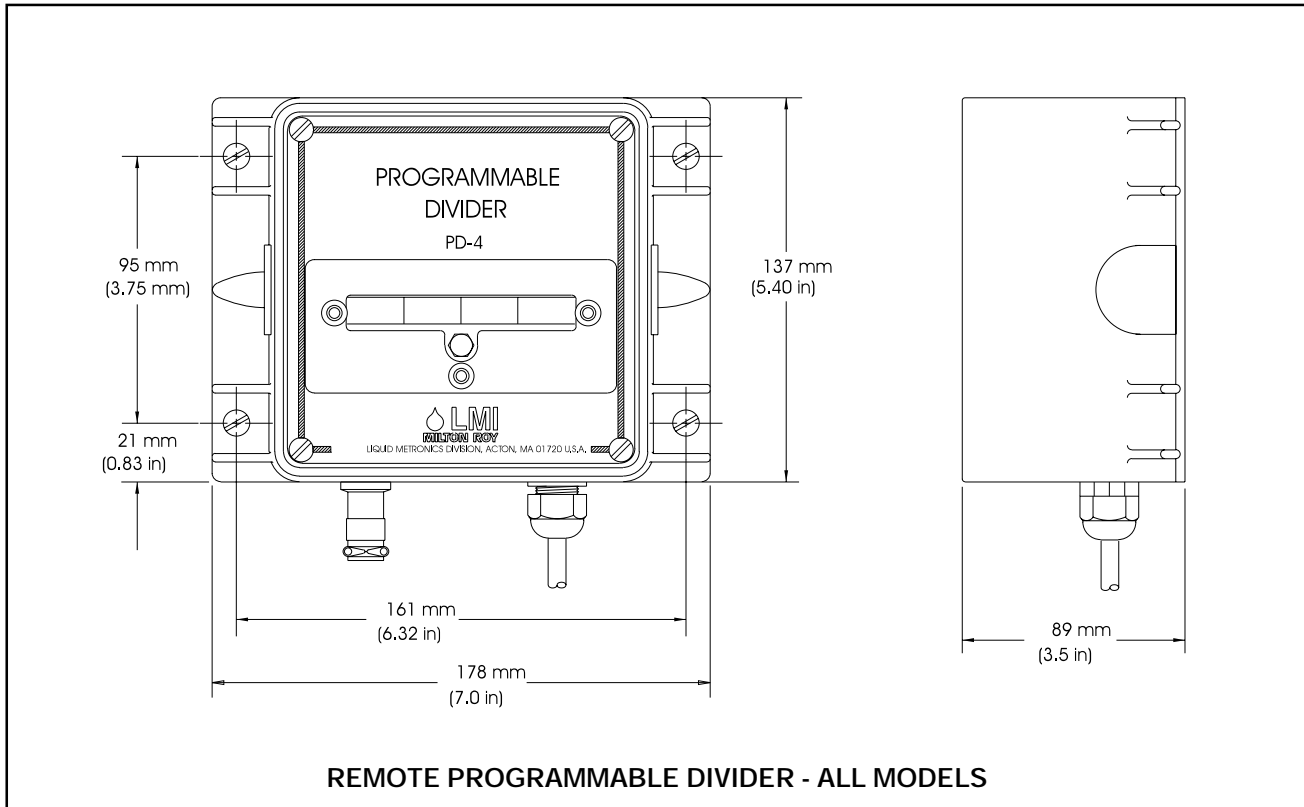

## SPECIFICATIONS

### **RFP-07, RFP-10, RFP-15, RFP-20**

**TYPE:** Multi-jet Impeller Meter

**BODY:** Bronze

**REGISTER:** Straight reading US Gallons, protected by high impact resistant plastic, permanently hermetically sealed .

7 digit totalizer on RFP-07 and RFP-10

8 digit totalizer on RFP-15, RFP-20

**SERVICE TEMPERATURE:** 32 to 120 °F (0 to 50° C).

**MAXIMUM OPERATING PRESSURE:** 200 psi (13.8 Bar)

### **RFP-30, RFP-40, RFP-60**

**TYPE:** Magnetic Drive Turbine Meter

**BODY:** Bronze

**REGISTER:** Straight reading US Gallons, center sweep hand, protected by high impact resistant plastic, permanently hermetically sealed between a glass dome and metal housing.

8 digit totalizer

**SERVICE TEMPERATURE:** 32 to 130° F (0 to 55° C)

**MAXIMUM OPERATING PRESSURE:** 150 psi (10.3 Bar)

**RFP meters comply with or exceed all AWWA Class I Turbine meter performance standards.**

## PARTS LIST

Part No.	Description	Quantity per Assembly							Program. Divider All Models
		RFP-07	RFP-10	RFP-15	RFP-20	RFP-30	RFP-40	RFP-60	
31271	Remote Programmable Divider Asm.	1	1	1	1	1	1	1	
31135	Housing								1
26740	Gasket Asm.								1
31277	Connector Asm.								1
31278	Cable Asm.								1
30990	Divider Asm.								1
26314	Switch								1
26490	Thumb Screw								3
28707	Screw, Self Tapping								4
10678	Screw, PH SS								4
31272	Panel Asm.								1
31256	Standoff								4
31110	Nameplate								1
28793	Wire Asm.								1
31374	Sensor Asm. w/ 8 Pin Cable	1	1	1	1				
31408	Sensor Asm. w/ 8 Pin Cable					1			
31409	Sensor Asm. w/ 8 Pin Cable						1		
31410	Sensor Asm. w/ 8 Pin Cable							1	
31670	Register Asm.	1							
31671	Register Asm.		1						
31672	Register Asm.			1	1				
26605	Register Asm.					1			
26606	Register Asm.						1		
31696	Register Asm.							1	
31673	Turbine Asm.	1							
31674	Turbine Asm.		1						
31675	Turbine Asm.			1					
31676	Turbine Asm.				1				
31431	Coupling Gasket (Mylar)	1							
31434	Coupling Gasket (Mylar)		1						
31437	Coupling Gasket (Mylar)			1					



8 Post Office Square  
Acton, MA 01720 USA  
TEL: (508) 263-9800  
FAX: (508) 264-9172  
<http://www.lmipumps.com>